

# Cyber Coach Free Resource

## Public Domain Document

Cover Sheet: cc\_pb\_ge99

Date published to web: 5/24/2000

Discussion ID: ge99

Courtesy of: Anonymous

Document Title: Coaches Playbook

Season(s) used: 2000

Age Group: 8-14 yrs

Grade(s): 3th through 7th

Description: A work in progress. More detailed than most. Suitable for coaches who want to develop a system to be used year after year. This book is a work in progress that has been developed over 6 seasons. It can be adapted in whole or part to fit most coaches needs.

The passing game is lacking as well as more description on the defenses. (As we have said this is a work in progress. There may be errors in consistency of terminology , grammar, etc.).

Courtesy of Cyber\_Coach: <http://www.cyber-shack.net/CyberCoach/>



# ***Football***



# ***Coaches Manual***

# Offensive Play Call

The play call is made up of six parts.

1. The **Formation**
2. The **Set or Series**
3. The **Back** and **Hole** Number
4. The **Type** of play
5. The **Blocking** pattern
6. The **Cadence** (when to snap the ball)

For instance a play will be called in the huddle as:  
PI Lft 22 DIV VR

Later on you will learn that it means the following:

FORMATION	SET	BACK	HOLE	TYPE	BLOCKING
<b>PI</b>	Left	<b>2</b>	<b>2</b>	<b>Dive</b>	Veer Right

If drawn on a blackboard it would look like this.

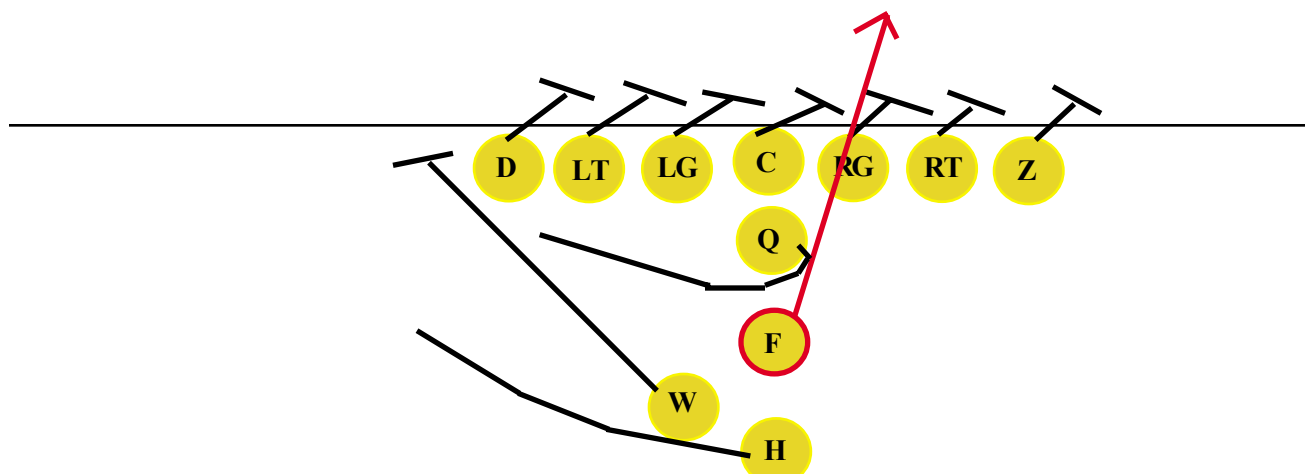

**2** Back, **2** Hole, **I** Formation = P I Left 22 Dive Veer Right

# *Offensive Positions*

- X** Wide Receiver (X). Will always play ON the line of scrimmage. Goes out for passes and blocks. Back number (6).
- LT** Left Tackle. Blocks. Position is number 3 hole. Lineman number (3).
- LG** Left Guard. Blocks. Position is number 1 hole. Lineman number (1).
- C** Center. Snaps ball to Quarterback and Blocks. Position is number 0 hole. Lineman number (0).
- RG** Right Guard. Blocks. Position is number 2 hole. Lineman number (2).
- RT** Right Tackle. Blocks. Position is number 4 hole. Lineman number (4).
- Z** Tight End (Z). Goes out for passes but mainly Blocks. Back number (5).
- Q** Quarterback (Q). Takes snap from center to start play. Will both run and pass. Back number (1).
- F** Fullback (F). Will carry ball, receive passes, and Block. Back number (2).
- H** Halfback (H). Will carry ball, receive passes, and Block. Back number (3).
- W** Wingback (W). Will carry ball, receive passes, and Block. Back number (4).

# Numbering System

The following are how the holes in the offensive line are numbered. Right even, Left odd.

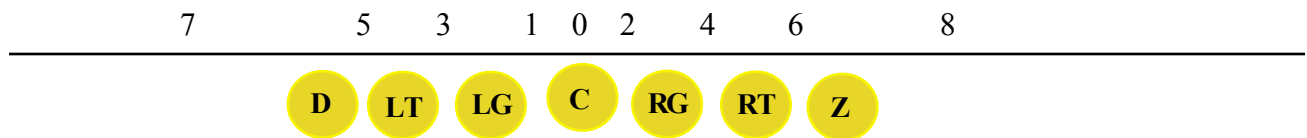

The following are how the offensive backs are numbered.

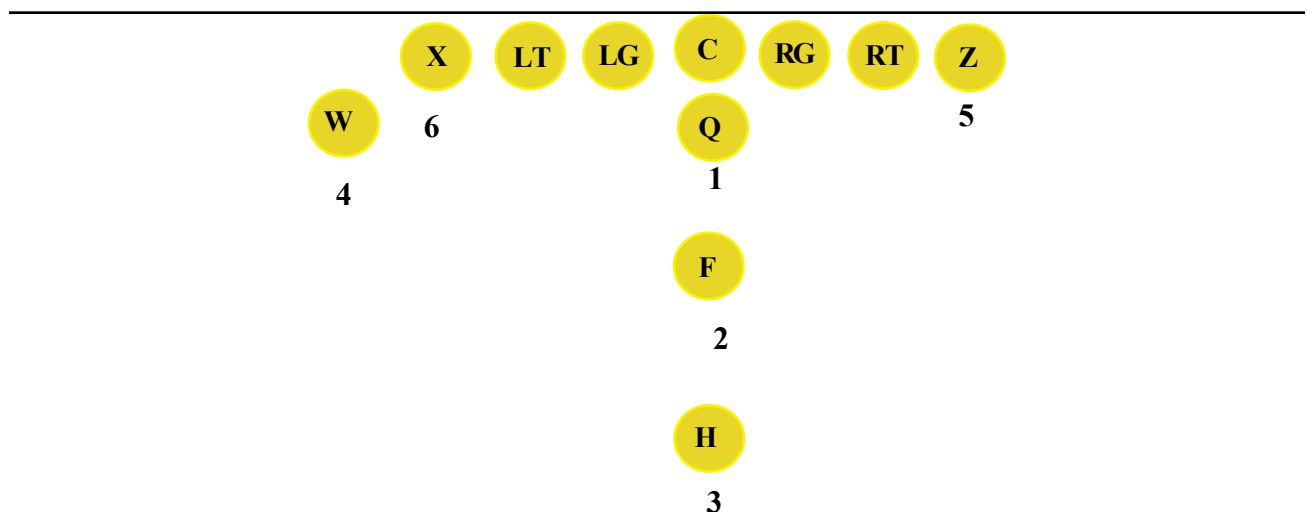

# Offensive Formations

(Four Basic Formations)

**I & PI & T & P**

Note: There are 14 positions shown in each formation. Only 11 players will be on the field at the same time.

## **I** <----Formation

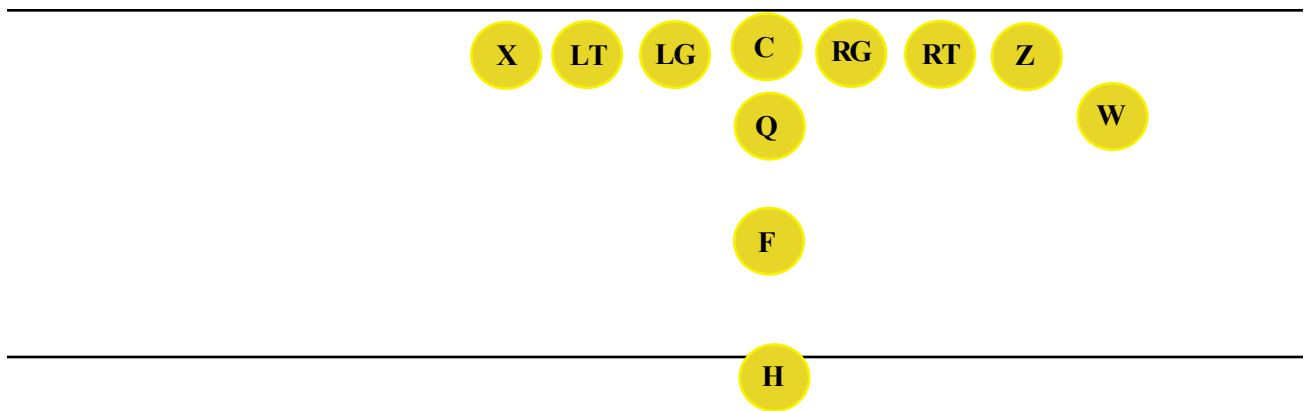

## **PI** <----Formation

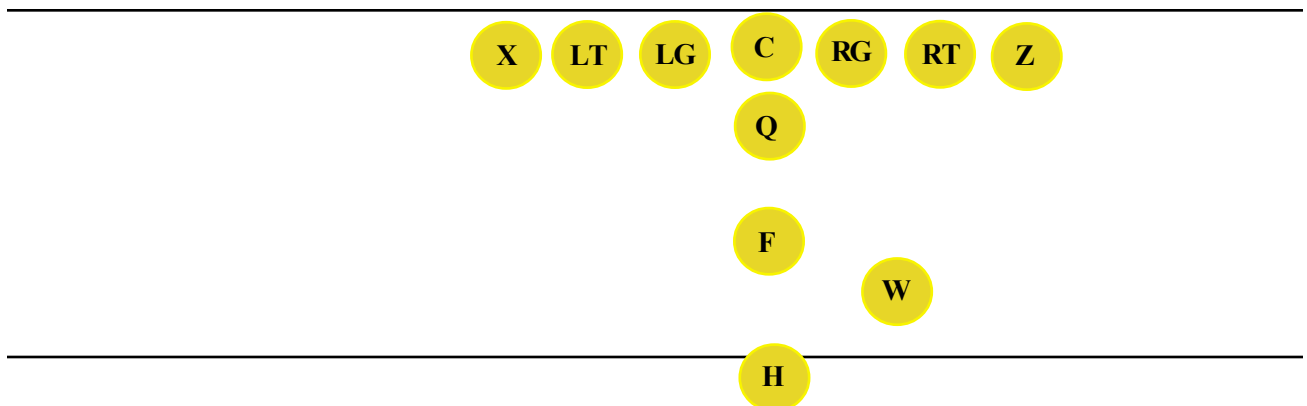

# Offensive Formations

## **T** ←---Formation

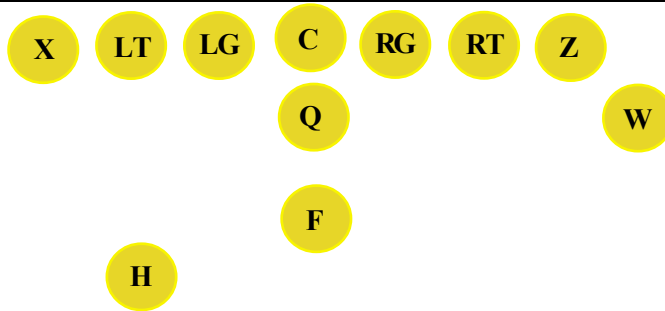

---

## **P** ←---Formation

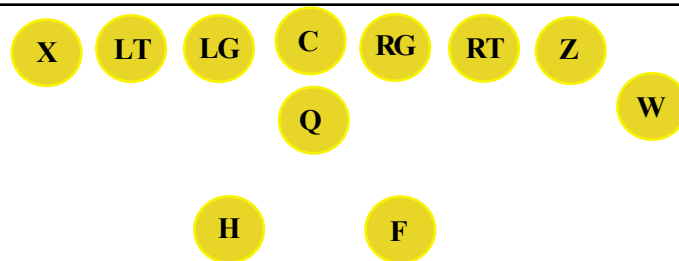

# Offensive Sets

An offensive “SET” is nothing more than where players line up in a formation. It is the second part of the play call. When a player's letter is called, he moves to a new position. Only a few players need to learn what to do on changing SETs.

These positions need to know how to change SETs.

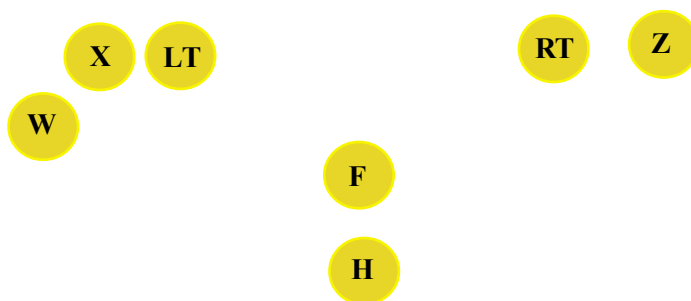

Lets begin by converging positions LT and RT.

## Basic Set

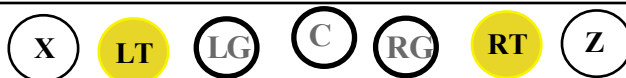

If the Quarterback in the huddle calls “Strong Left” the RT moves to the opposite side of the line inside D.

## Set Strong Left



If the Quarterback in the huddle calls “Strong Right” the LT moves to the opposite side of the line inside Z.

## Set Strong Right



This is ALL positions LT and RT will have to know about the “SETs”.

# Offensive Sets

These positions (X & Z) will need to know how to change “SETs”.

## Basic Set

---



If the Quarterback in the huddle calls “Split”, “Split Left”, or “Split Right”, the X and Z receivers will move as shown and both remain on the line of scrimmage.

If the Quarterback in the huddle calls “Split” the X and Z receivers both line up in a wide out (split) position.

## Split Set

---



If the Quarterback in the huddle calls “Split Left” the X receiver lines up in a split position.

## Split Left Set

---



If the Quarterback in the huddle calls “Split Right” the Z receiver lines up in a split position.

## Split Right Set

---



This is ALL positions X and Z will have to know about the “SETs”.

# Offensive Sets

These positions will need to know how to change “SETS” in both the T and I Formations.

## Basic Set for T Formation

---

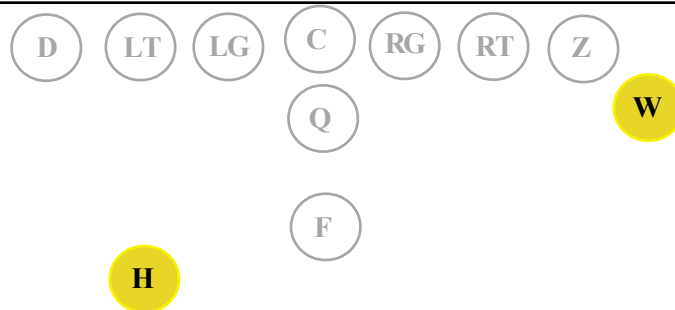

In the T Formation if “Left is called the H Back and W Back moves to their new positions.

## Left Set for T Formation

---

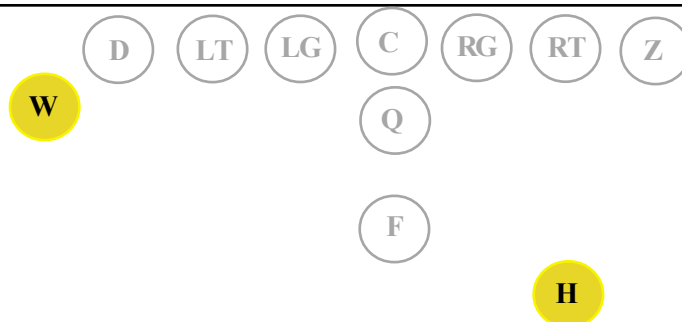

# Offensive Sets

In the I Formation the W back lines up in the following basic formation.

## Basic Set for I Formation

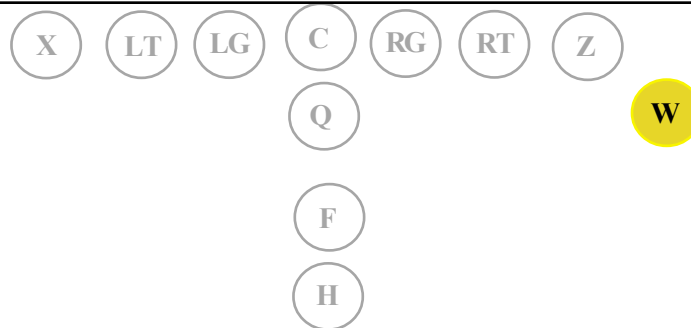

In the I Formation if “Left” is called the W back lines up in the in the same position on the left side.

## Left Set for I Formation

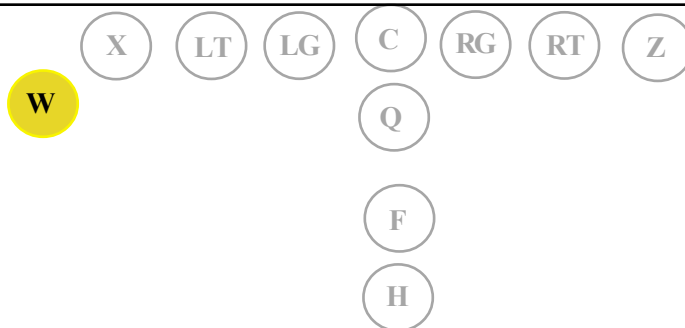

# Offensive Sets

In the I Formation if “Split” is called the W back moves to a slot position on the right side.

## Split Set for I Formation

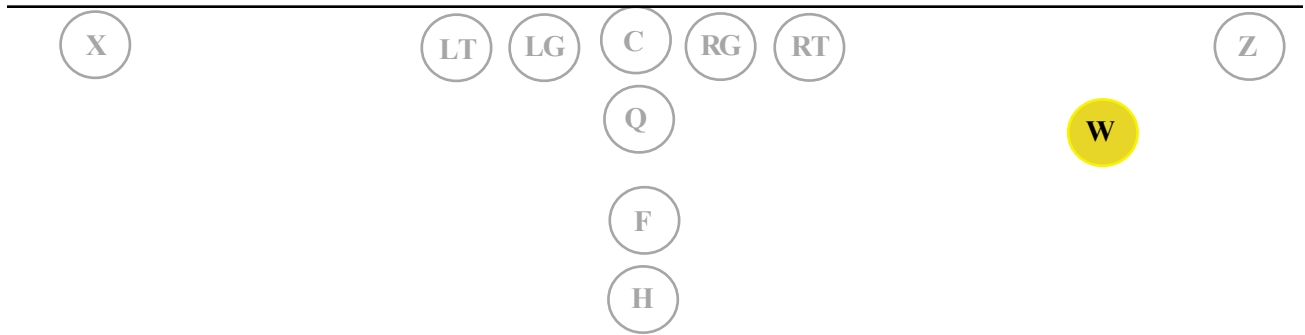

In the I Formation if “Split Right” is called the W back moves to a slot position on the right side.

## Split Right Set for I Formation

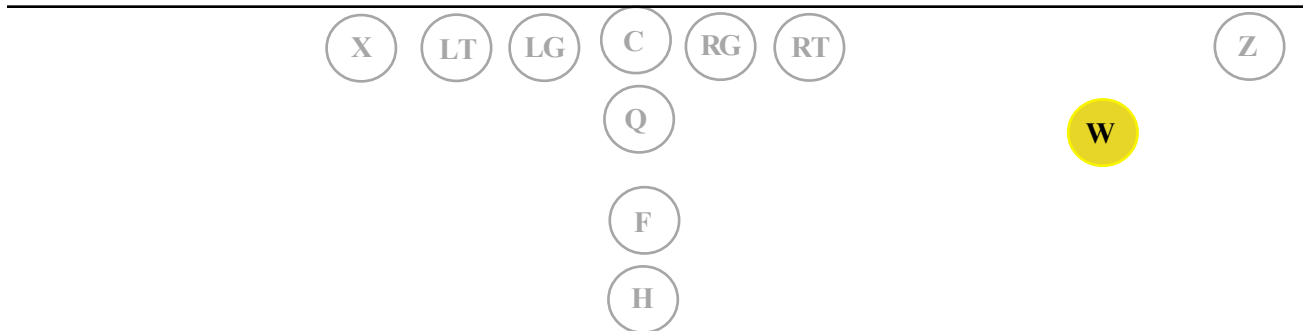

In the I Formation if “Split Left” is called the W back moves to a slot position on the left side.

## Split Left Set for I Formation

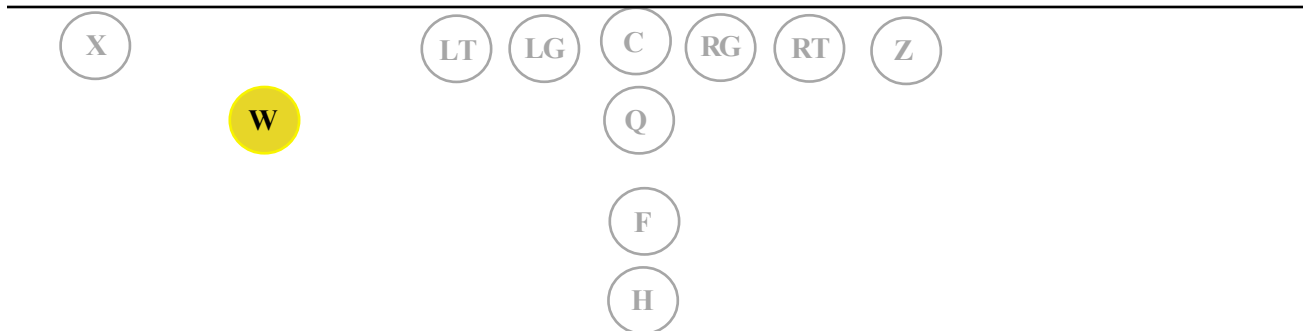

# Offensive Sets

This is the Basic Set for the PI Formation.

## Basic Set for PI Formation

---

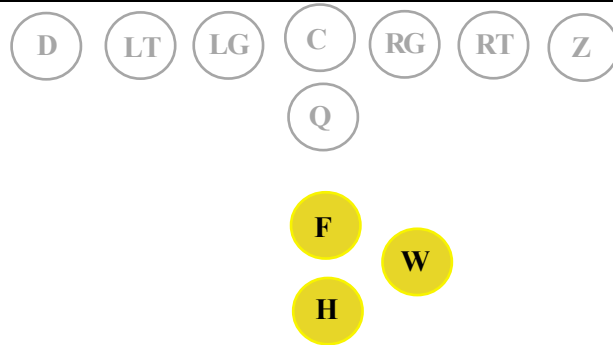

In the I Formation if “Left” is called the W Back moves to the same position on the left side.

## W Set for PI Formation

---

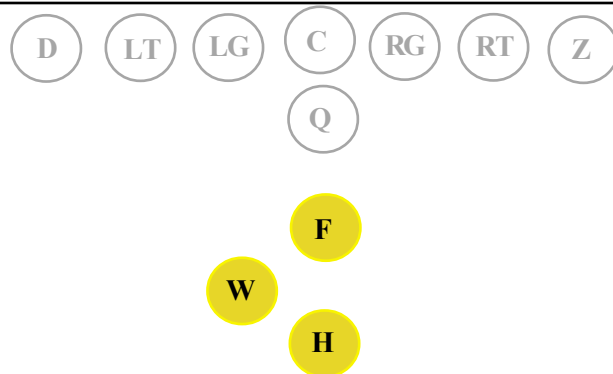

# Offensive Sets

This is the Basic Set for the P Formation.

## Basic Set for P Formation

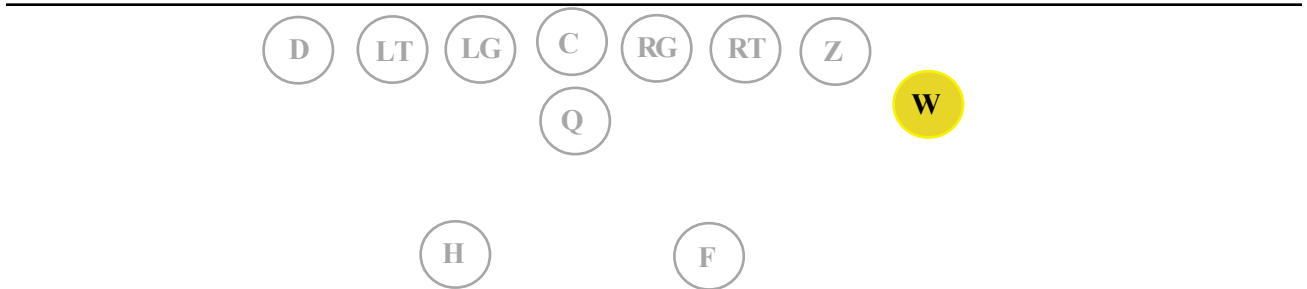

The rules for the P formation for the W back are the same as in the I formation.

## Basic Set for P Formation

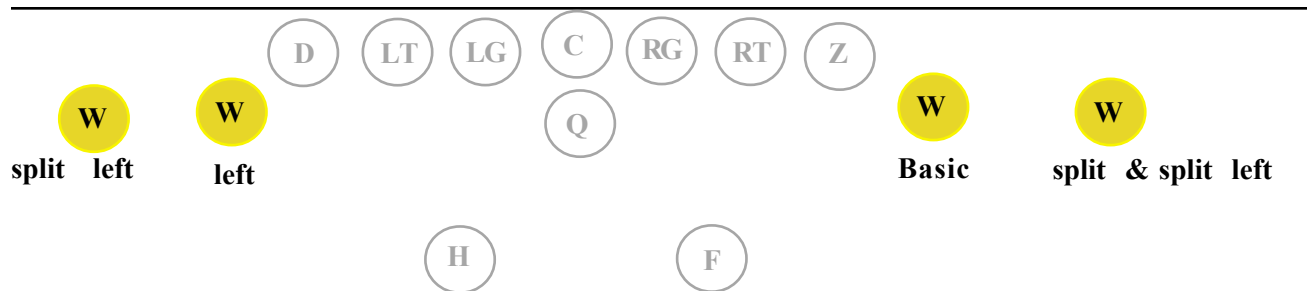

# Line Blocking

**Blast Blocking** is the simplest blocking pattern.

*All Blocking will be Blast unless called a blocking pattern is called in the huddle.*

**Rule:** If there is a defender across from you in the inside gap, that is your first priority. If no defender is in the gap then you block the man directly in front of you either at the first or second level.

## Blast.

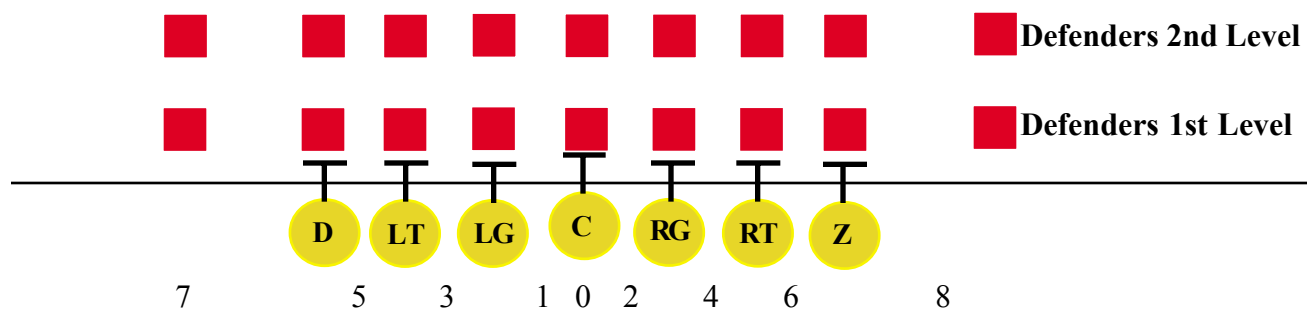

# Line Blocking

**Blast.**

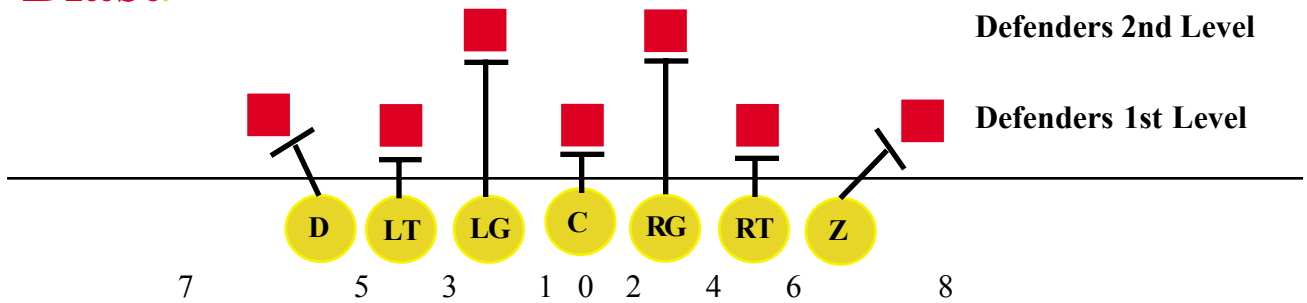

**Blast.**

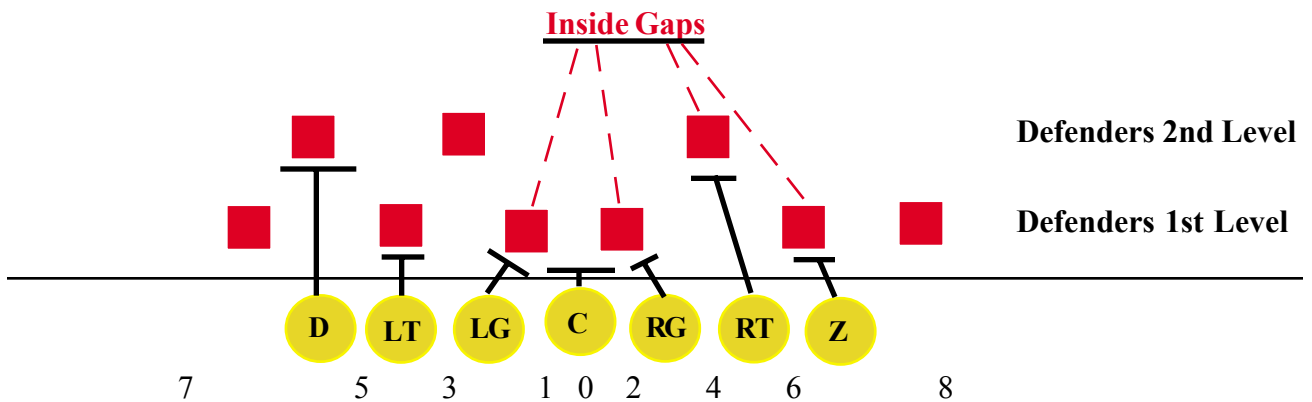

# Line Blocking

VR - “Veer Right”.

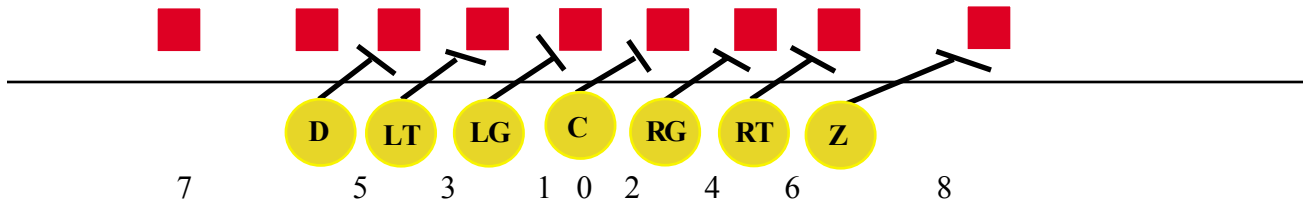

VL - “Veer Left”.

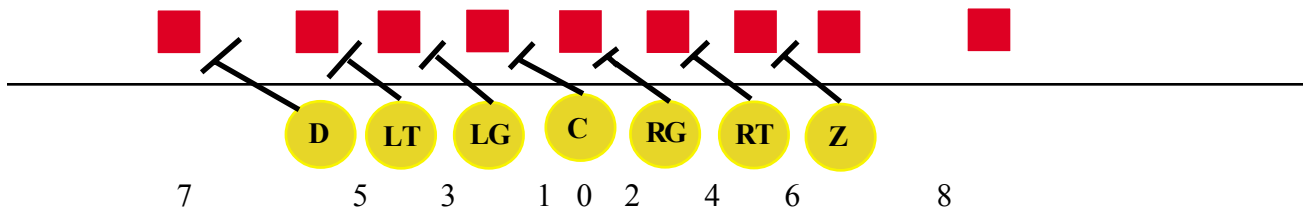

PL - “Pull” lineman / hole”.

Example PL 16 - “Pull” 1 lineman / 6 hole”.

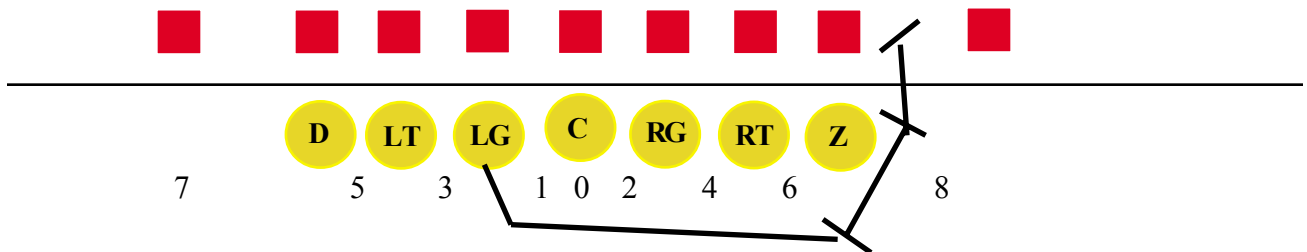

# Line Blocking

CR - “**Cross** “1st lineman / 2nd lineman””.

**Rule:** 1st lineman number called goes **First**.  
2nd lineman sidesteps and goes **Next**.

**Example CR 24 - “Cross “2 & 4 lineman””.**

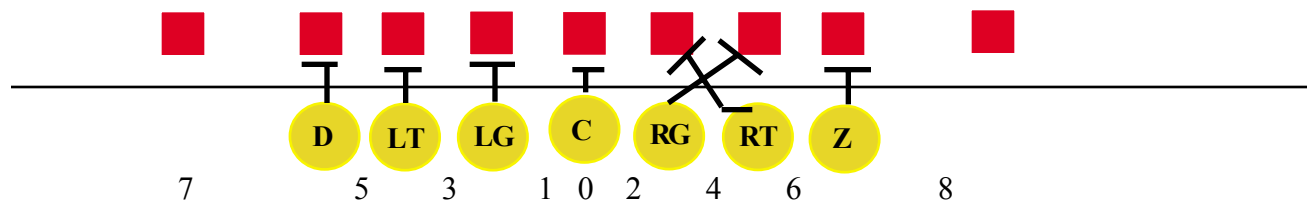

**Example CR 53 - “Cross “5 & 3 lineman””.**

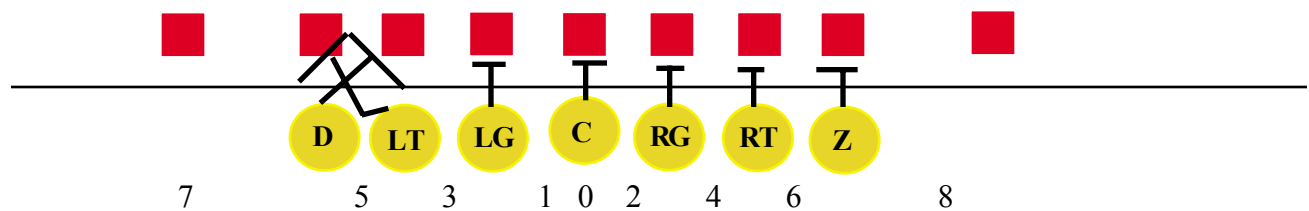

# Line Blocking

## SR - "Slide Right"

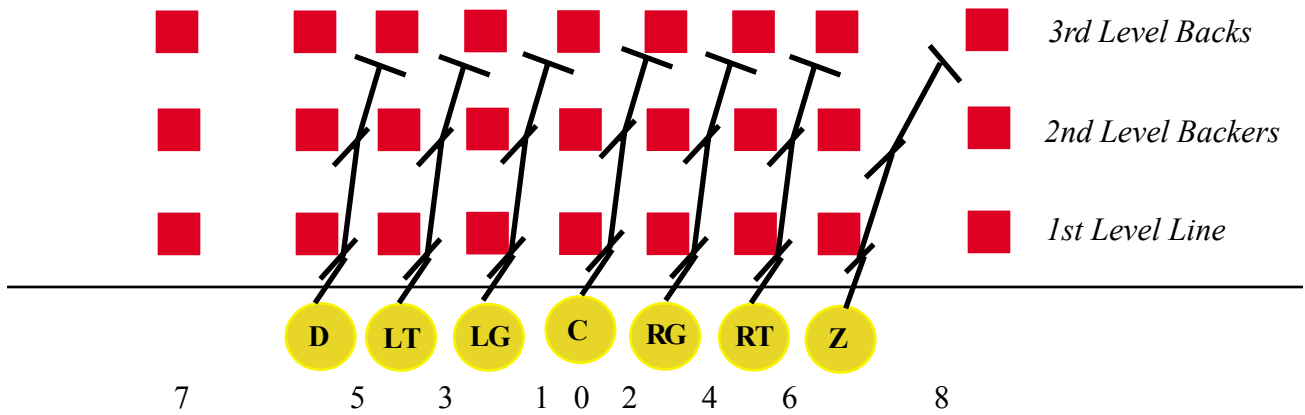

## SL - "Slide Left"

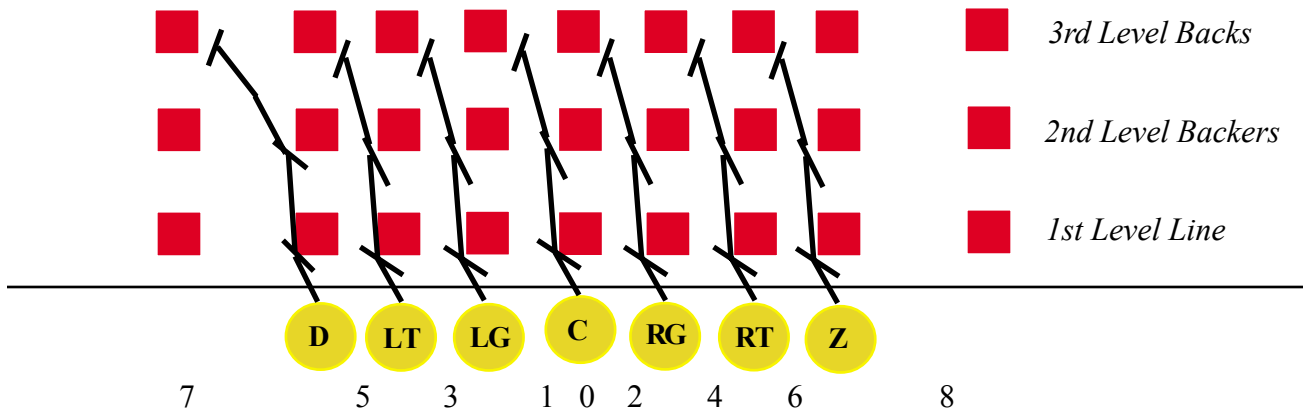

# Line Blocking

## OR - “Open Right”.

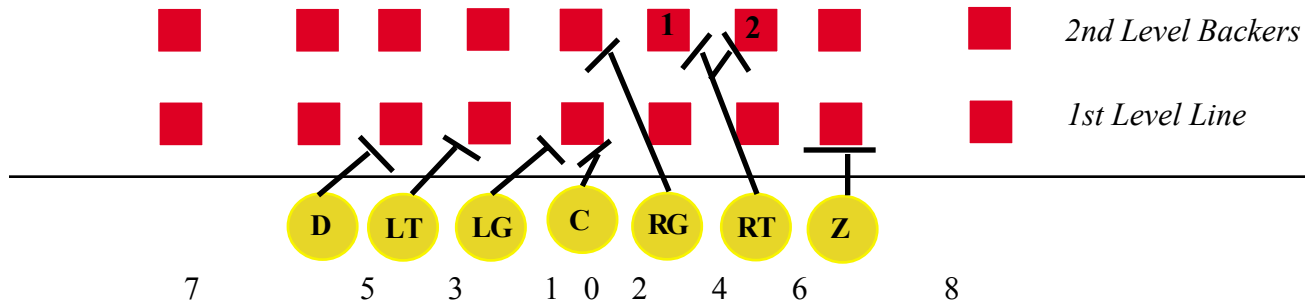

## OL - “Open Left”.

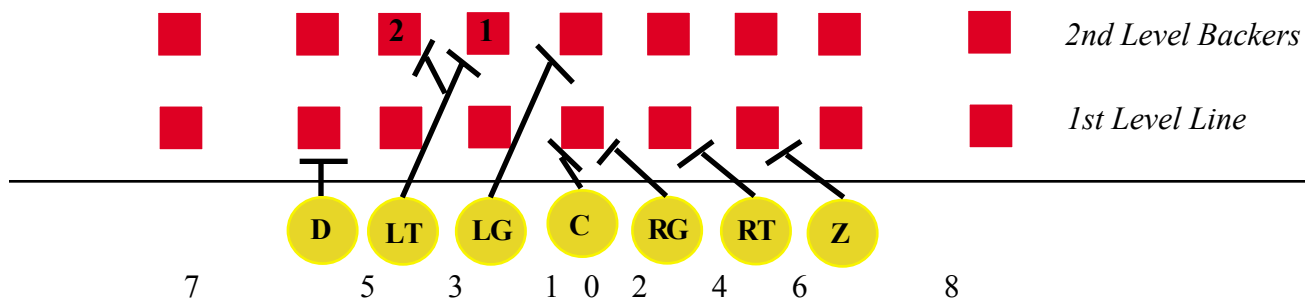

# Line Blocking

## TD - “Tight End Double”.

*The tight ends and offensive tackles double teams the defensive tackles.*

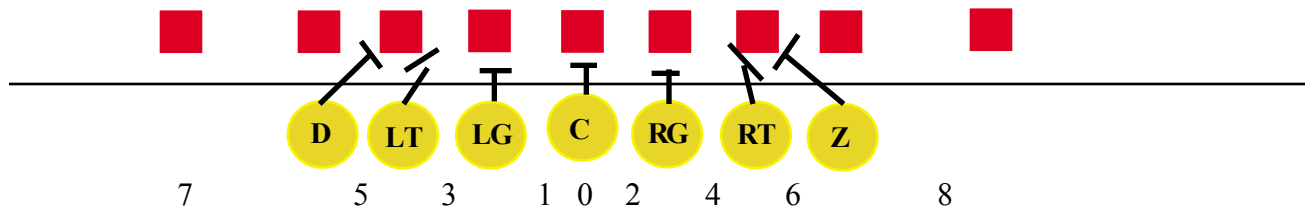

## TR - “Trap” “lineman / behind hole”.

**Example TR 16 - “Trap”** “1 lineman / behind 6 hole”. Lineman blocks behind line.

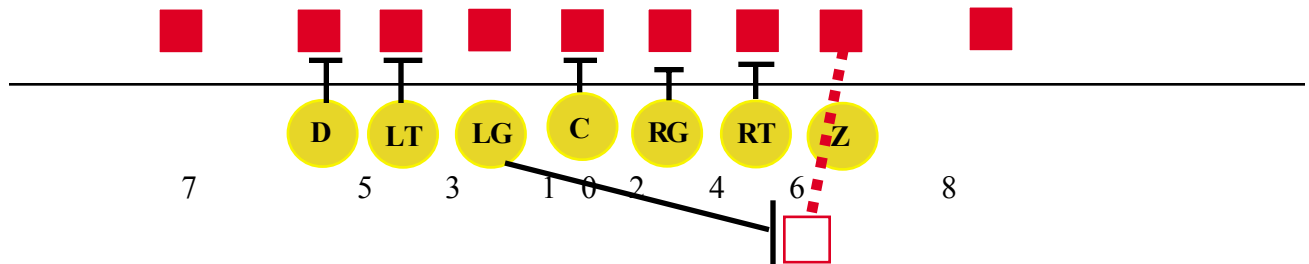

**Rule:** *Remaining linemen block blast unless they are involved in a pattern.*

**Rule:** *Combination blocking patterns may be called;*

*(i.e. VR & PL 28). The & symbol is pronounced as “AND”.*

# Type of Play

**Dive:** A dive play is where the QB hands off to a back who runs directly to the hole.

## 22 Dive

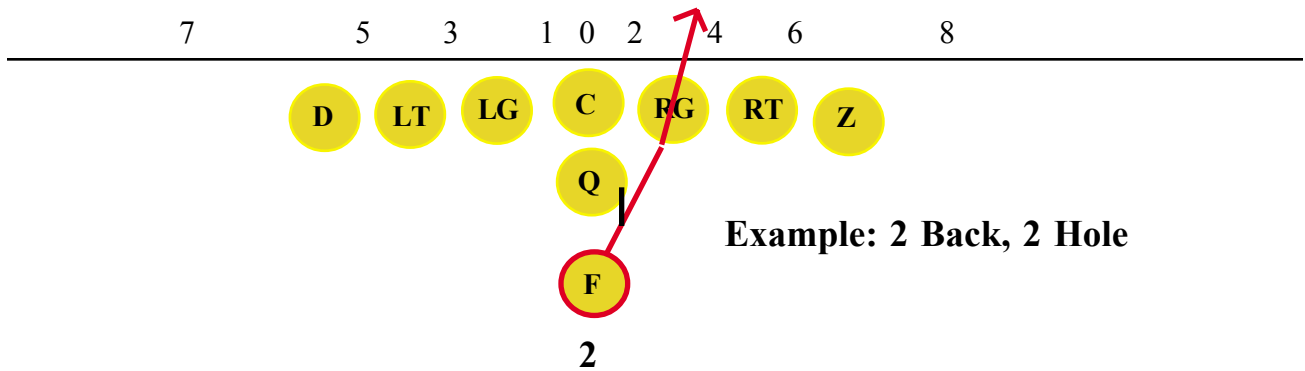

**Power Dive:** A dive play is where the QB hands off to a back who runs behind the other backs who block.

## 35 Power Dive

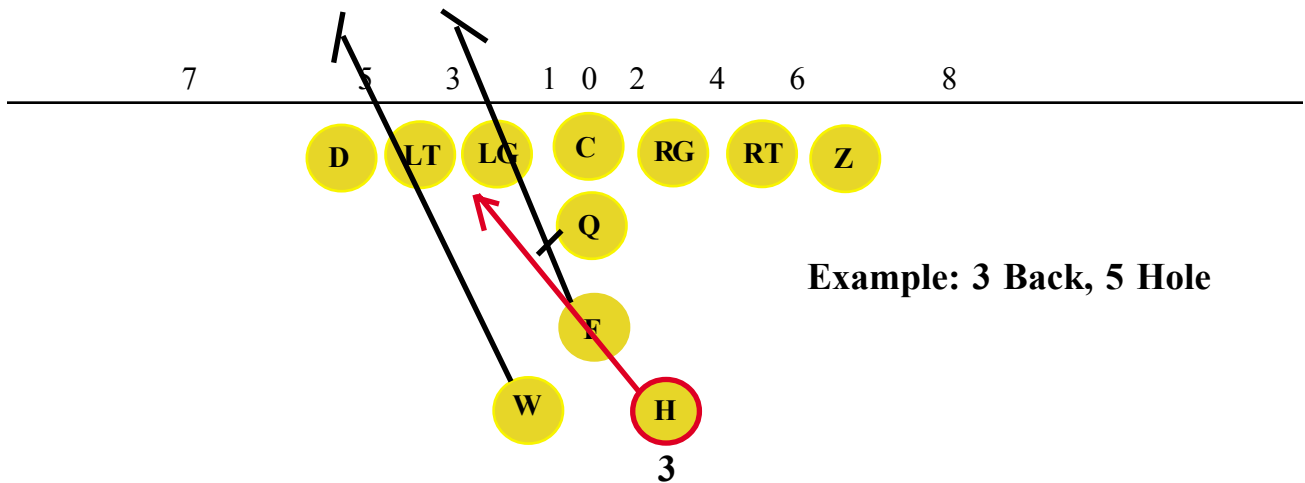

# Type of Play

**Counter Dive:** A dive play is where the play action is opposite of the direction of the play.

## 44 Counter Dive

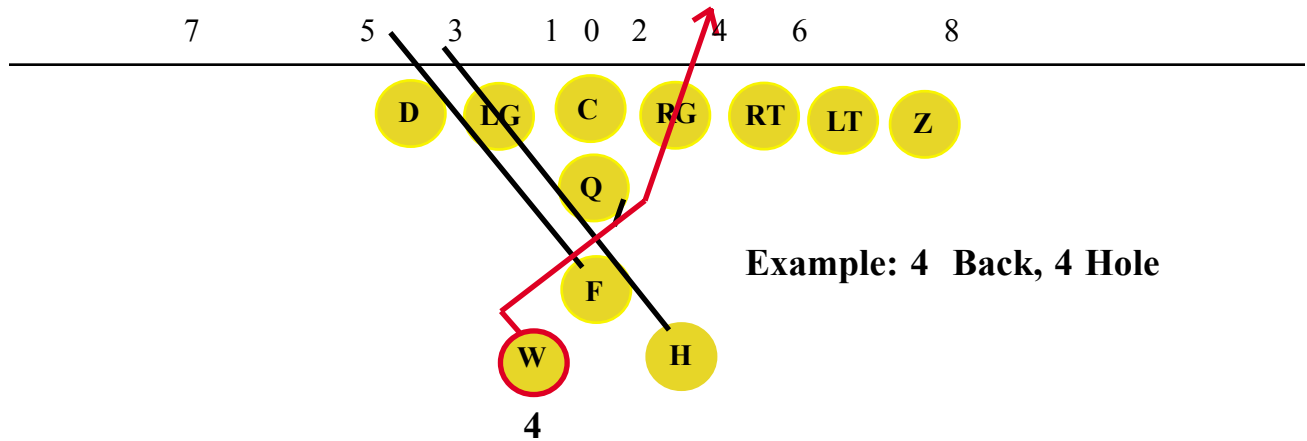

**Option:** A option play is where the QB determines who will carry the ball based on what the defense does.

## 38 Option

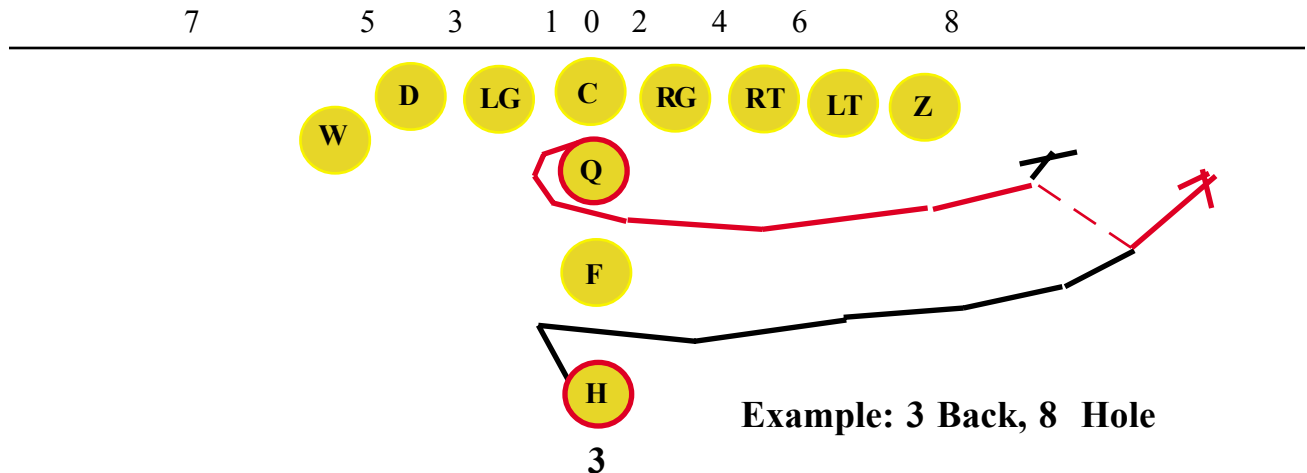

# Type of Play

**Counter Option:** A option play where the flow of the play is opposite of the hole.

## 48 Counter Option

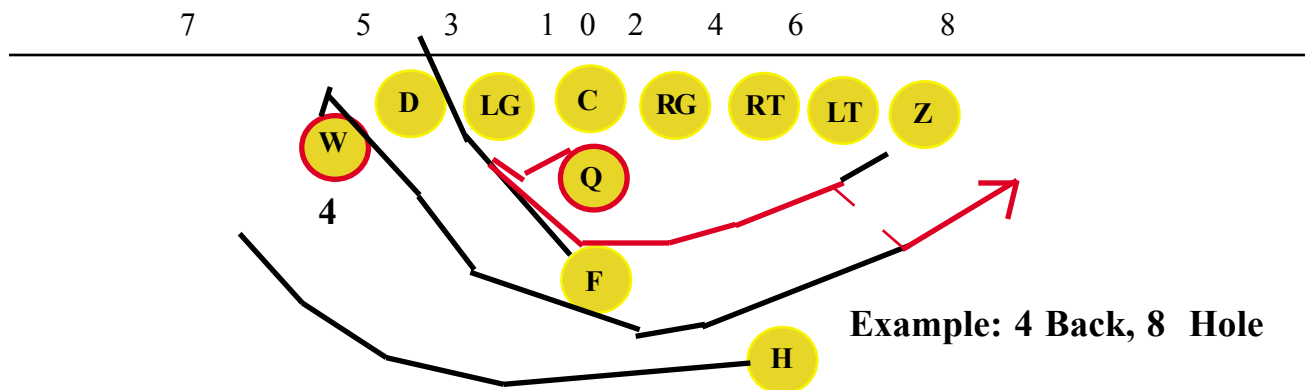

**Pitch:** A pitch play is where the QB immediately turns and tosses the ball to a back who is already moving to the hole.

## 38 Pitch

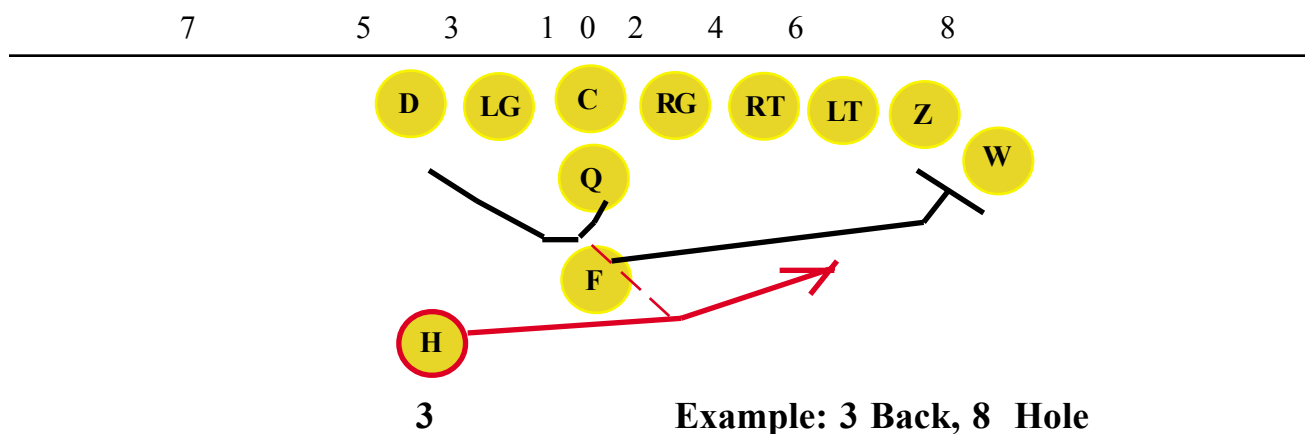

# Type of Play

**Boot:** A boot play is where the QB rolls out and can either run or pass.

## 17 Boot

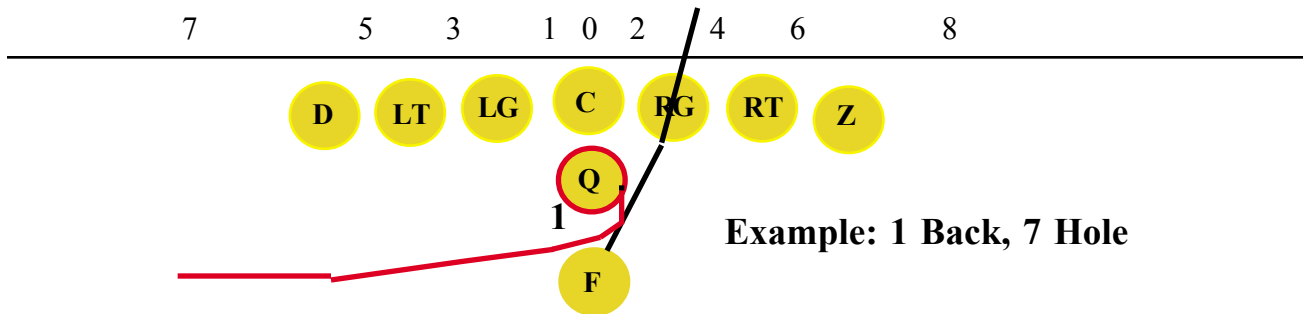

**Sweep:** A sweep play is where the QB hands off to a back who “sweeps” around the defensive flank.

## 38 Sweep

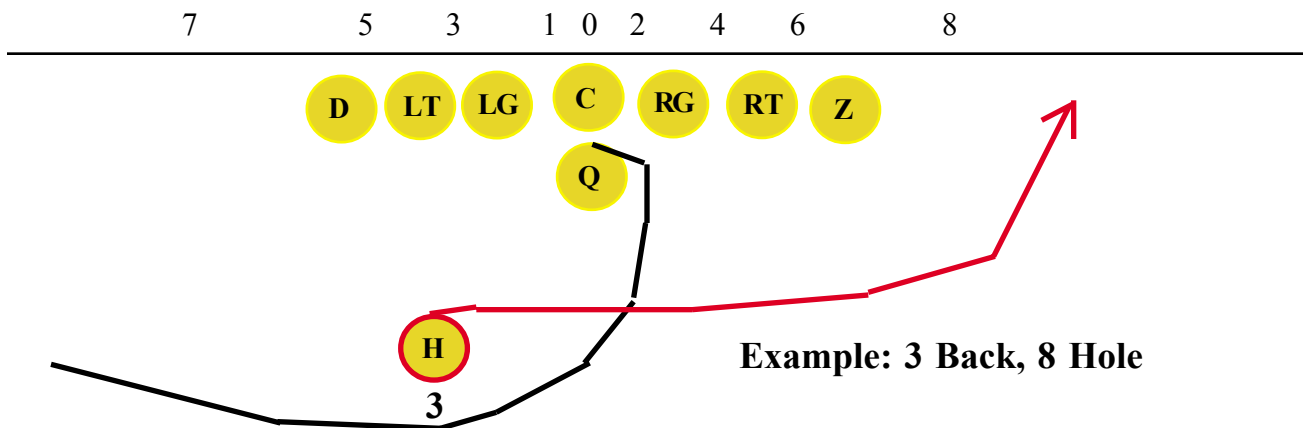

# Type of Play

**Sneak:** A sneak play is where the quarterback takes the snap and goes directly through the hole.

## 11 Sneak

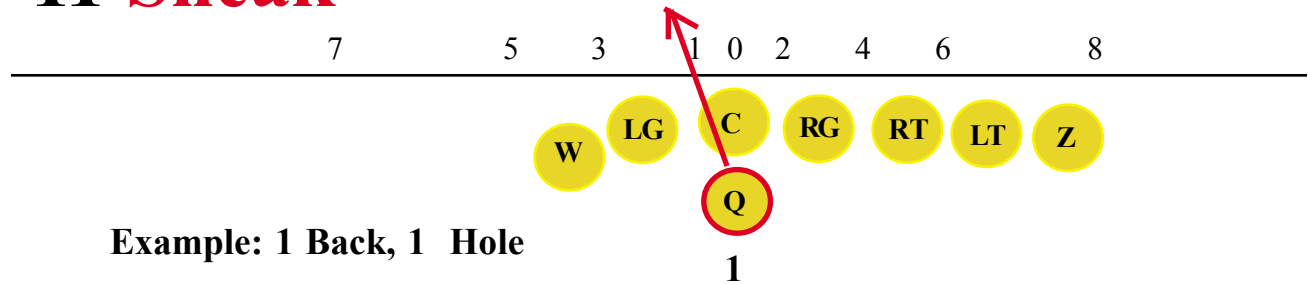

**Reverse:** A reverse play is where the play sweeps toward one direction and the ball is handed to a back moving in the opposite direction.

## 68 Reverse

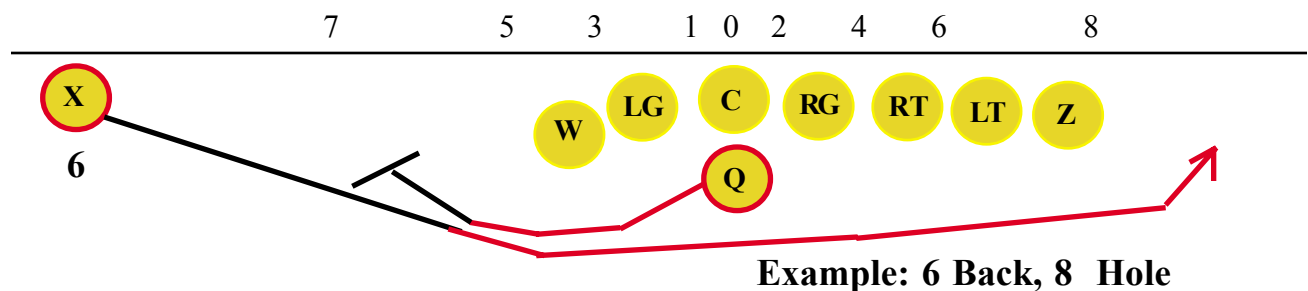

# Type of Play

A pass play is called as follows:

Formation	Set	Play	Reciver Number	Route
T	SR	Pass	5	Delay Out

The following are definitions of each pass route:

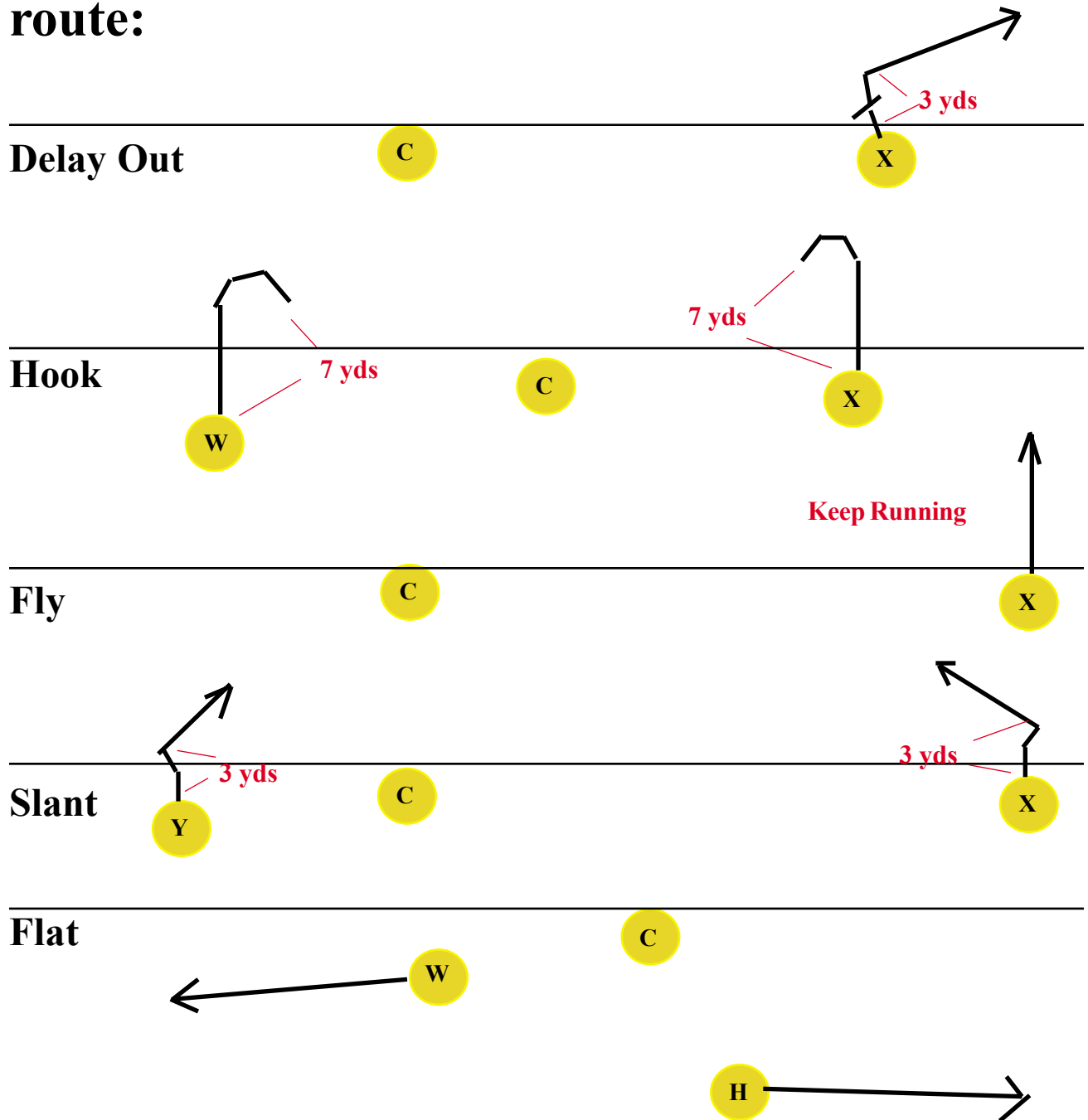

# Type of Play

**Pass:** A pass play is where the QB throws the ball to a receiver across the line of scrimmage.

## Pass 5 Delay Out

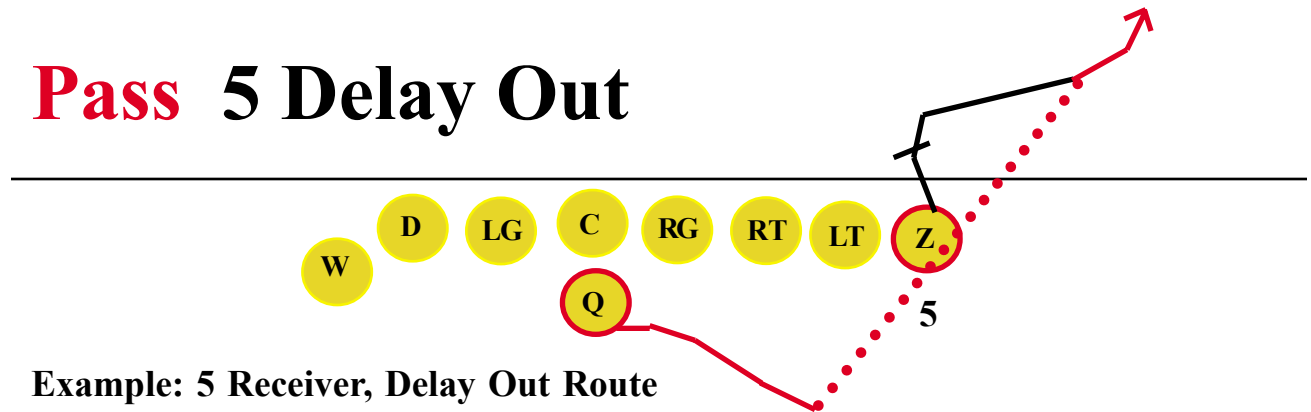

## Pass 4 Hook

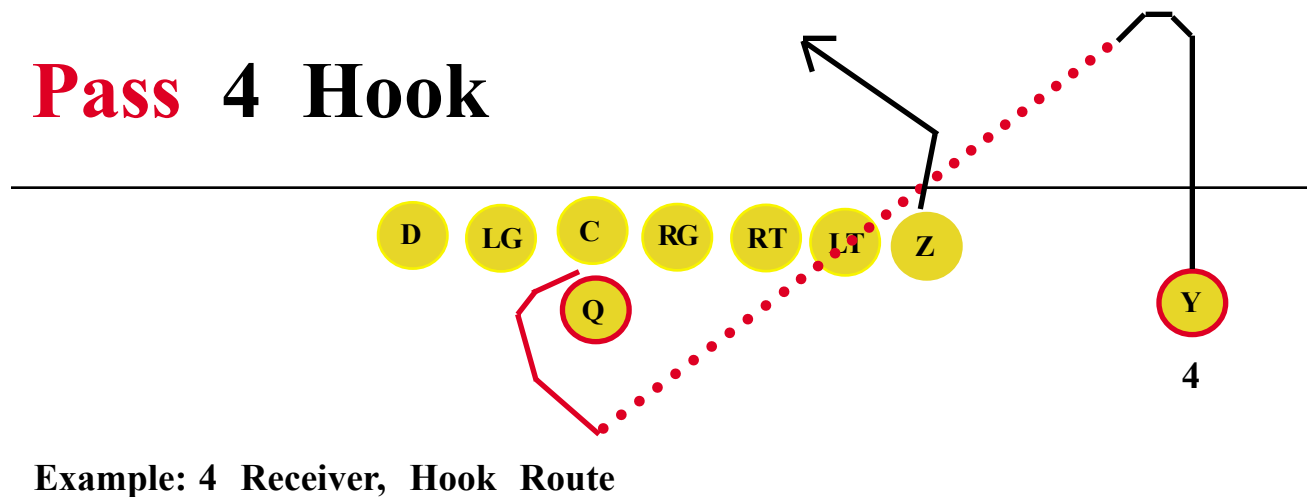

# Quarterback Key

## Sets

<b>Terms</b>	<b>Pronounced</b>
SR	Strong Right

## Plays

<b>Terms</b>	<b>Pronounced</b>
DV	Dive
PDV	Power Dive
CDV	Counter Dive
OP	Option
COP	Counter Option
PIT	Pitch
REV	Reverse
PAS	Pass
SNK	Sneak
SWP	Sweep
BOO	Boot

## Blocking Patterns

<b>Terms</b>	<b>Pronounced</b>
BLA	Blast
VR	Veer Right
VL	Veer Left
PL	Pull
&	and
SR	Slide Right
SL	Slide Left
OR	Open Right
OL	Open Left
PAS	Pass
TR	Trap
TD	TE Double Team

## Pass Routes

<b>Terms</b>	<b>Pronounced</b>
DO	Delay Out
HK	Hook
FY	Fly
SL	Slant
FT	Flat



**T Split 22 DV**

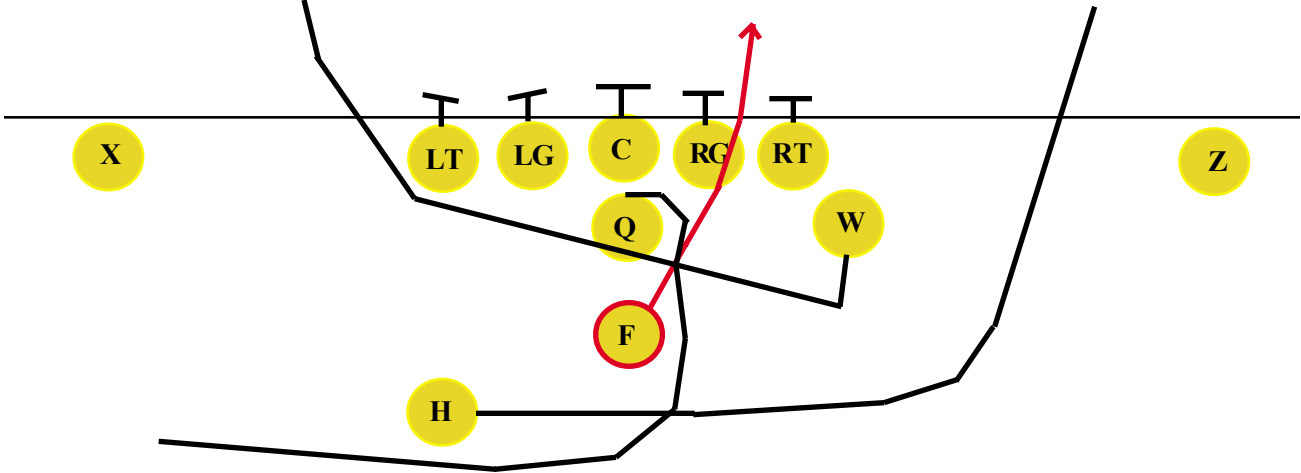

**T Split 22 DV SR & CR 42**

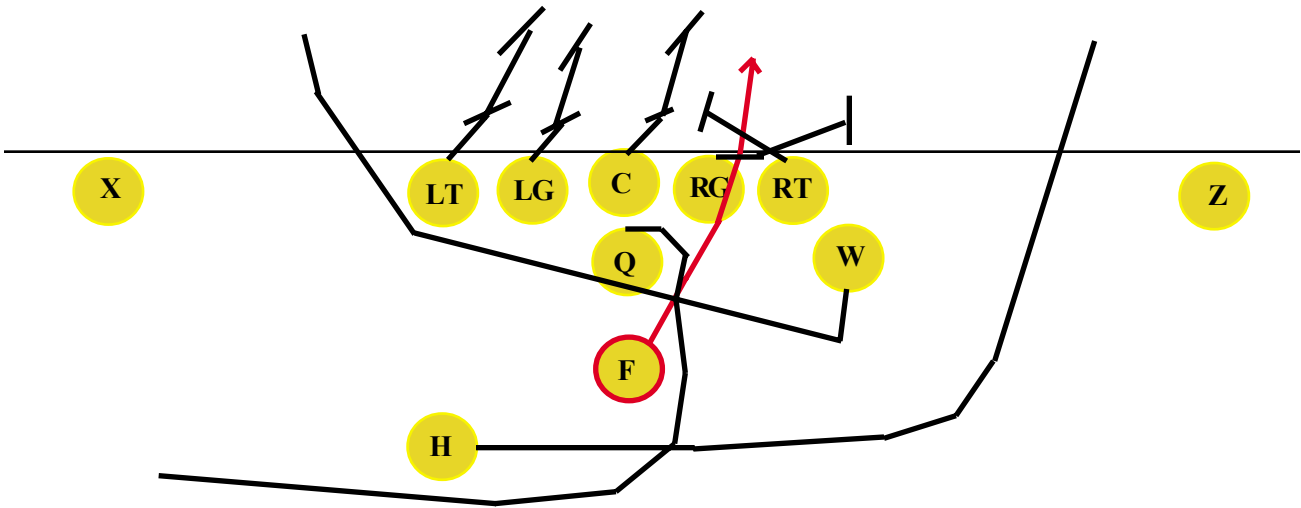

**T Split 45 CDV PL 25**

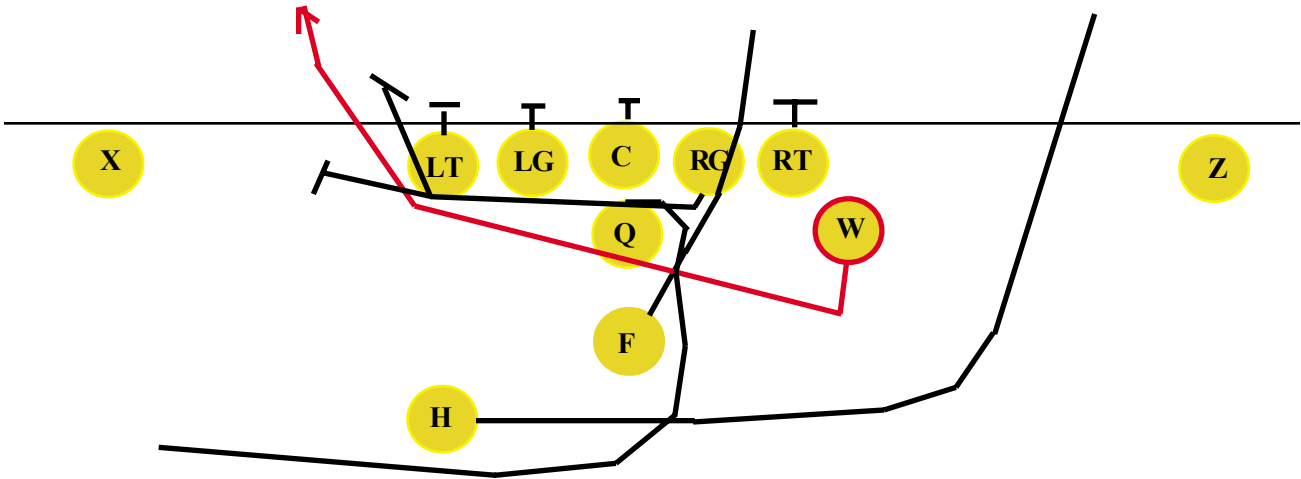

**T Split Strong Left 45 CDV VR**

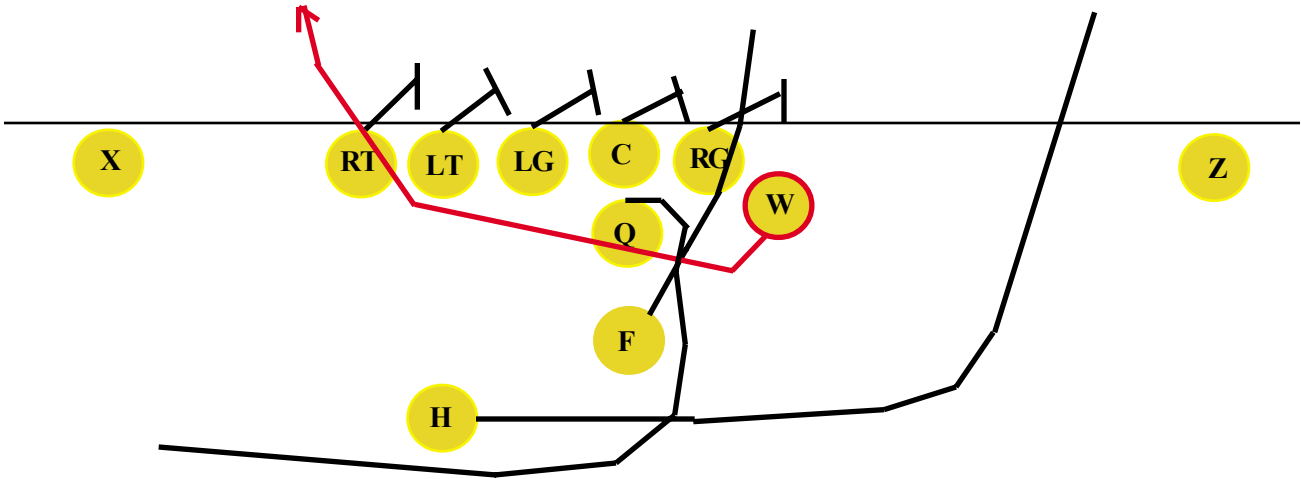

**T Split 38 SWP PL 28**

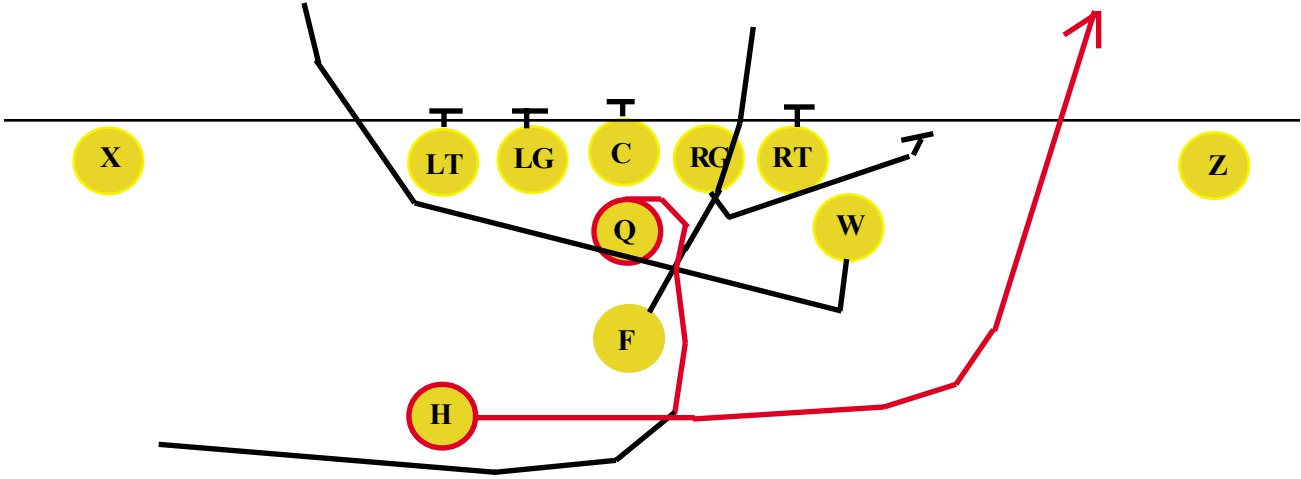

**T Split Strong Right 38 SWP VL & PL 28 & 48**

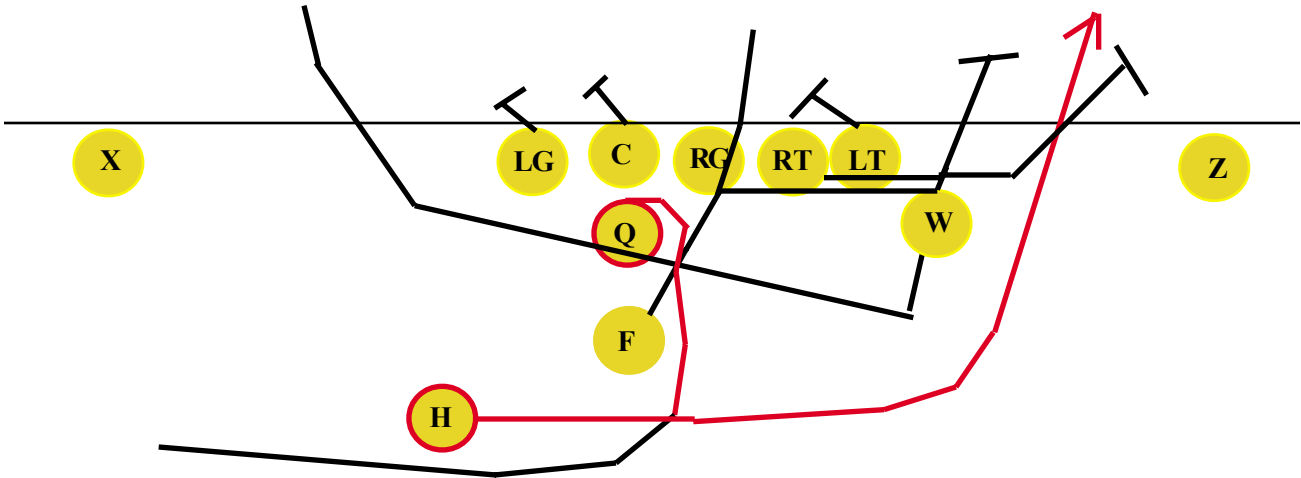

### T Split 19 Boot

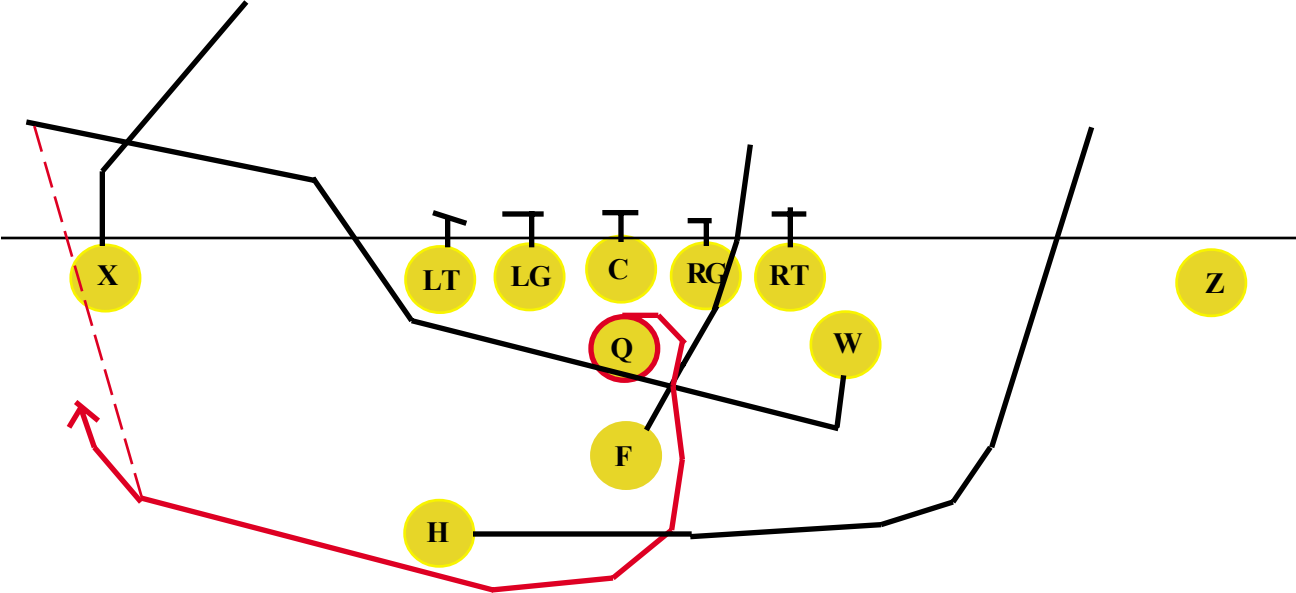

### T Split

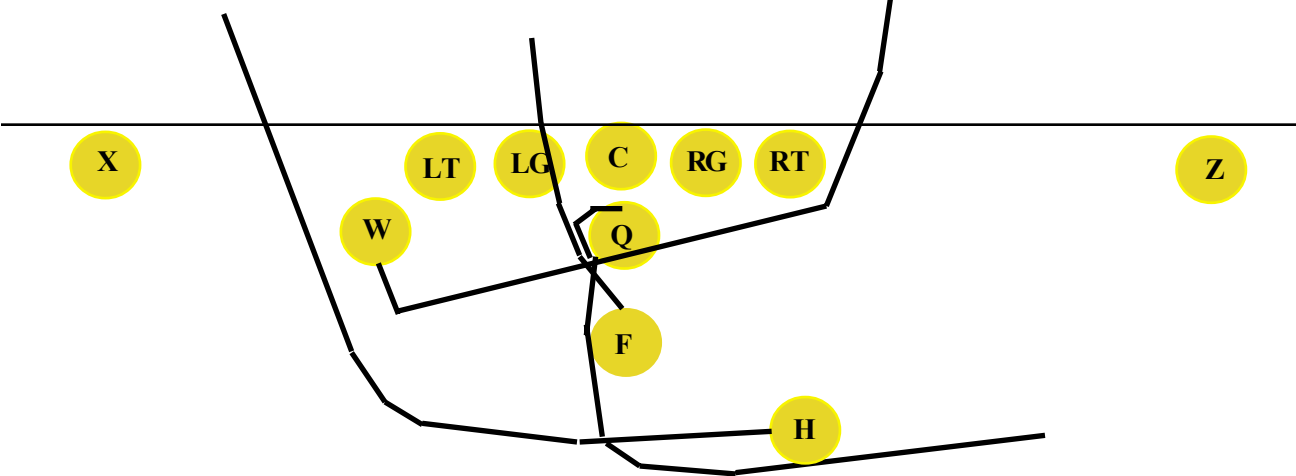

# I Split Left 36 CDV CR 64 & VR

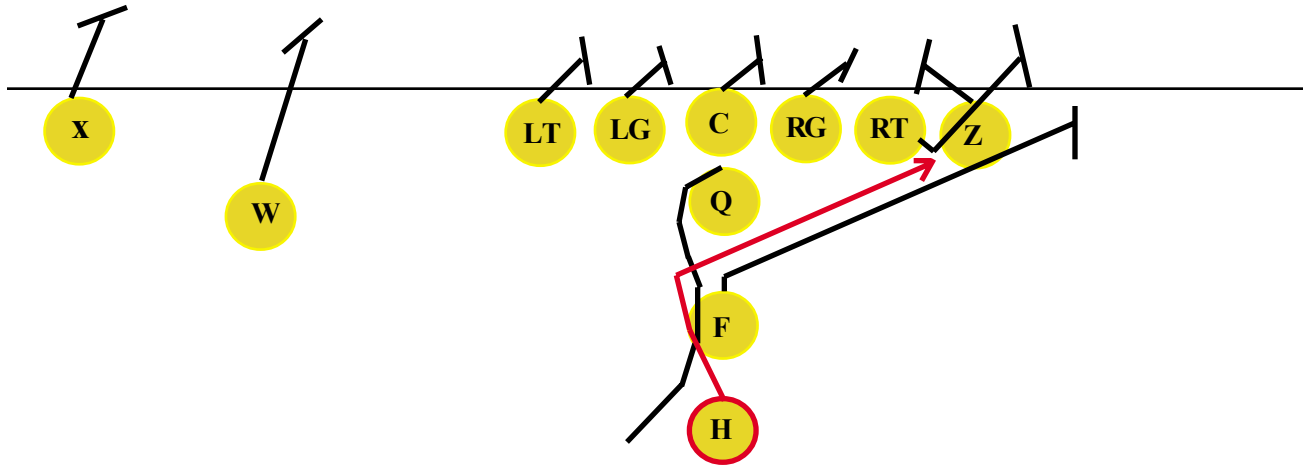

# I 34 Split Left CDV CR42 & VR

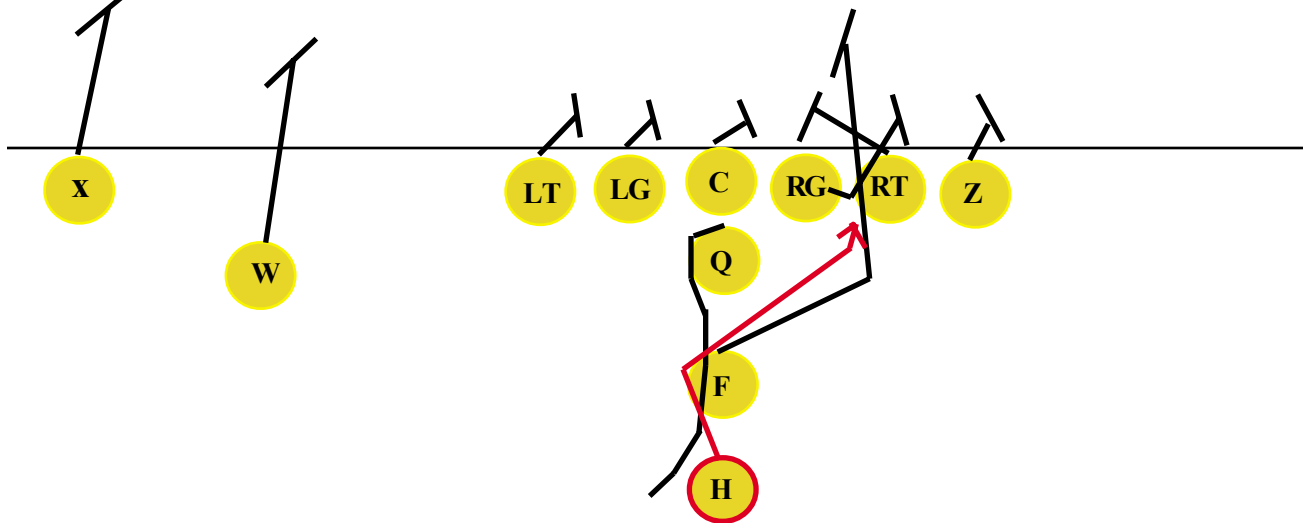

# I Split Left 32 CDV CR20 & VR

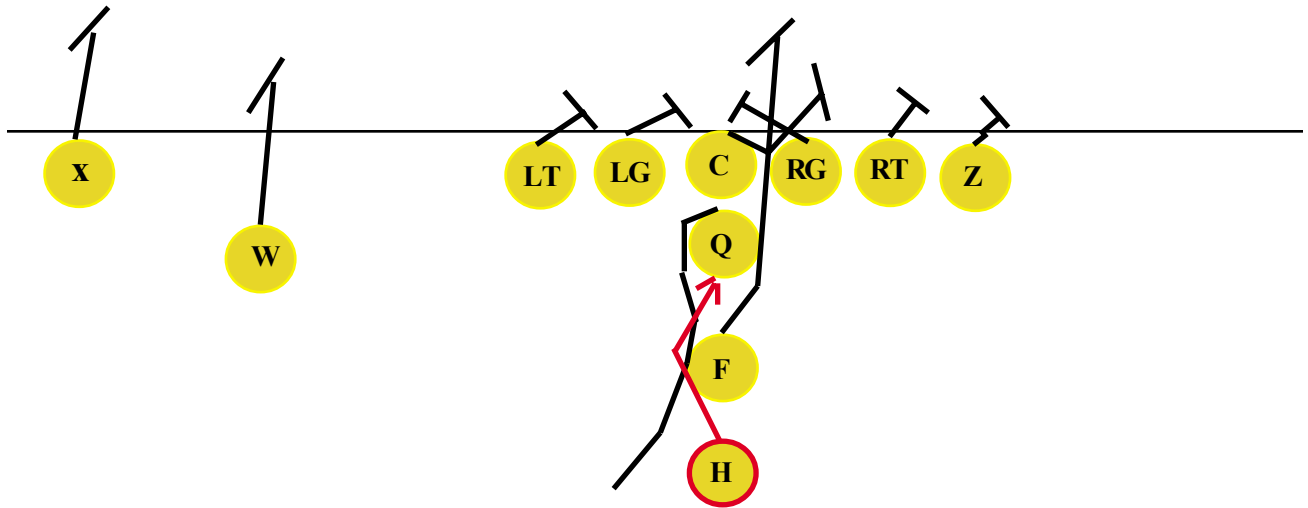

# I Split Left 31 CDV CR 31 & VL

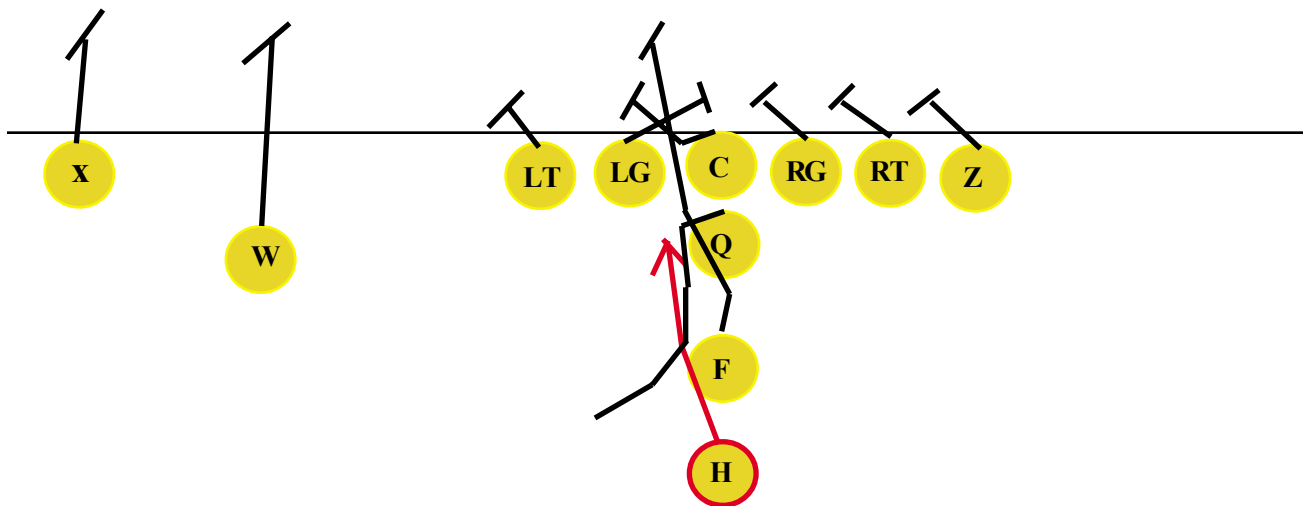

# I Strong Left 35 CDV VR

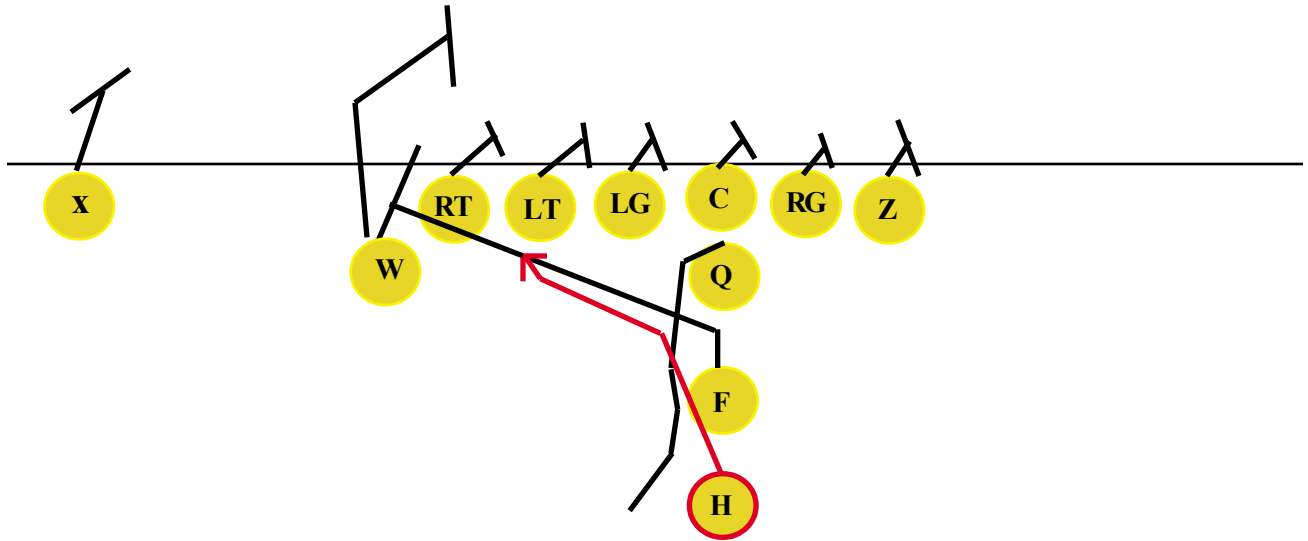

# I Split Left PAS 4 HK

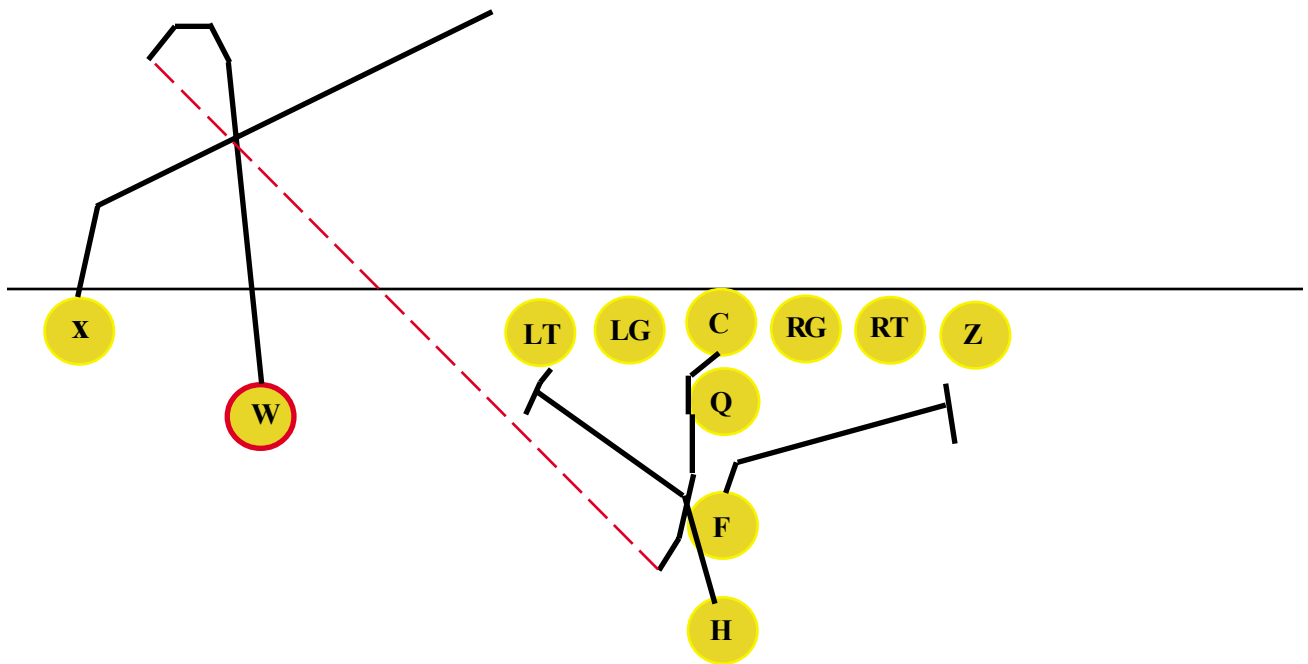



# *Defensive Positions*



Left End. Normally lines up on the outside shoulder of the tackle. Plays the run and rushes the passer taking an outside route to contain the play. “Soft Pursues.”



Right Tackle. Lines up over the guard or in a gap. When lining up in gap, shoots into backfield as quickly as possible. Plays the run and rushes the passer.



Left Tackle. Normally lines up over the guard or in a gap, but will play a line-backer in a 3-4 defense. Plays the run and rushes the passer.



Right End. Normally lines up on the outside shoulder of the tackle. Plays the run and rushes the passer taking an outside route to contain the play. “Soft Pursues.”



Left Linebacker. Plays the run and defends the pass. In pass coverage, picks up the first running back going out for pass on left side. Blitzes quarterback as assigned.



Middle Linebacker. Primarily defends the run. On passing plays, “mirrors” the quarterback and goes in for sack if there is an opening.



Right Linebacker. Plays the run and defends the pass. In pass coverage, picks up the first running back going out for pass on left side. Blitzes quarterback as assigned.



Left Cornerback. First responsibility is to defend pass to wide receiver, but also provides run support. On wide running plays, stays wide and forces play back inside.



Free Safety. Last line of defense. Primarily plays pass defense, but comes up to play the run ONLY AFTER the ball carrier crosses the line of scrimmage.



Strong Safety. Defends run and pass. Is responsible for covering tight end.



Right Cornerback. First responsibility is to defend pass to wide receiver, but also provides run support. On wide running plays, stays wide and forces play back inside.

# *Defensive Play Call*

**Defensive formations & blitzes will be called using hand signals. Formations will be called first on coach's left hand.**

- 1 - 4-3 Base
- 2 - 4-3 Attack
- 3 - 3-4 Attack
- 4 - 5-2 Attack
- 5 - Goal Line

**Then, blitzes will be called. Multiple combinations will be used.**

- 1 - Left Linebacker (inside blitz), blitz between guard and tackle.
- 2 - Left Linebacker (outside blitz), Left End goes inside of tackle and Left Linebacker takes outside path and keeps everything inside.
- 3 - Right Linebacker (inside blitz).
- 4 - Right Linebacker (outside blitz).
- 5 - Middle Linebacker.
- 6 - Free Safety.
- 7 - Right Cornerback.
- 8 - Left Cornerback.

**When a cornerback blitzes, the free safety will cover that receiver.**

# 5 - 3 Defense

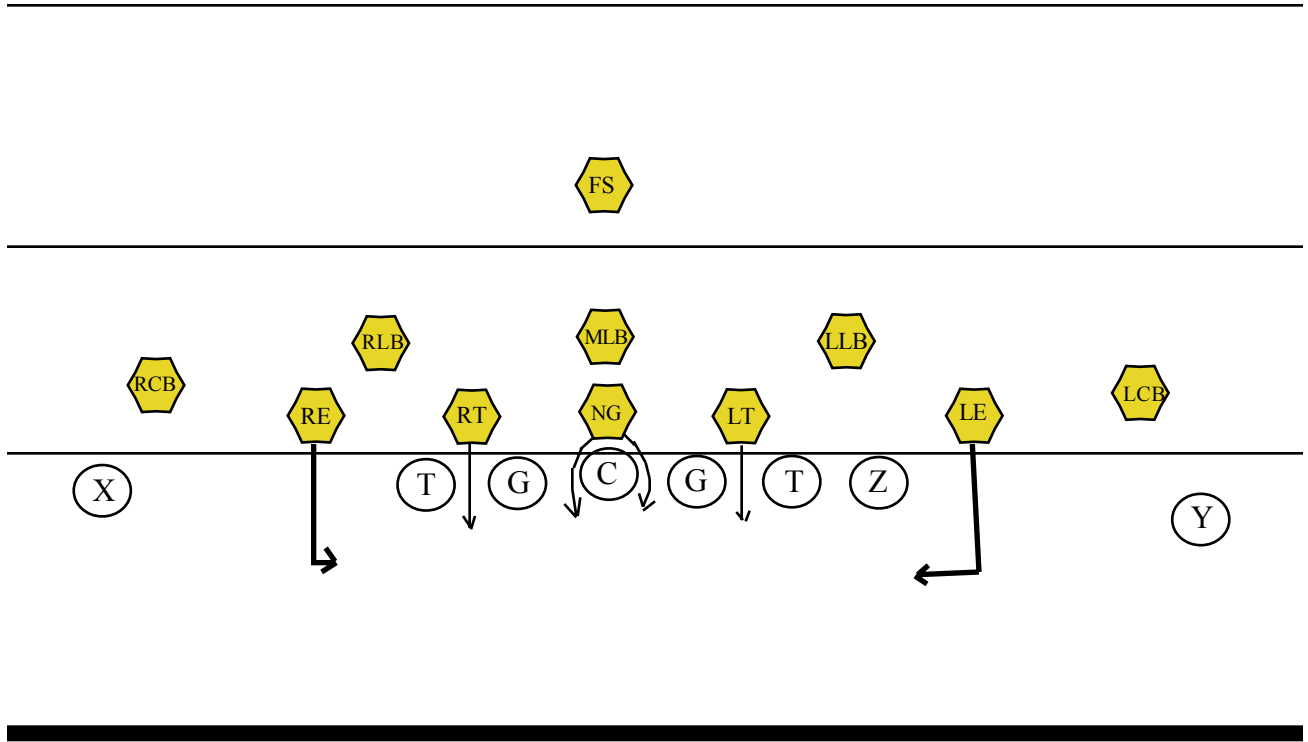

# 4 - 3 Attack

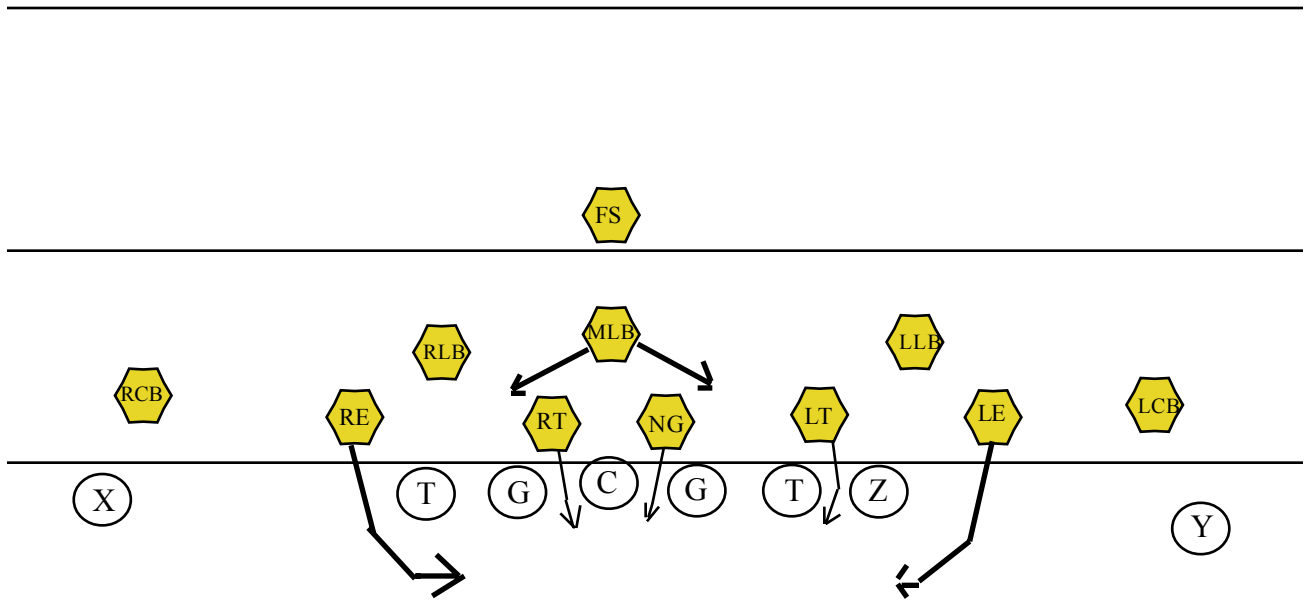

# 6 - 2 Defense

